

\*\*\* ENLARGED TO SHOW DETAIL

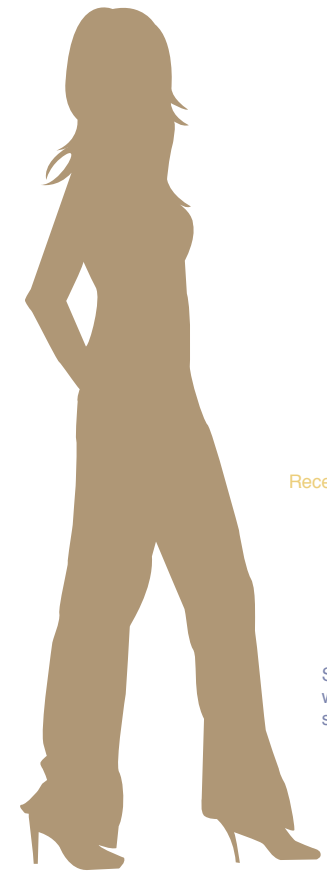

Vinyl lettering  
Color: Pantone 497C  
Type: Times



date 03/06/07

status FINAL

client ELEMENTS

design firm

**davis engineering**

JAMIE DAVIS  
623.398.9222  
301 W SEQUOIA DR  
PHOENIX, AZ 85027

project title  
**MENU BOARD**

location  
10320 E DYNAMITE BLVD  
SCOTTSDALE, AZ 85262

scale 3/4"=1'-0"

All designs as well as this drawing are the property of Davis Engineering and are © 2007

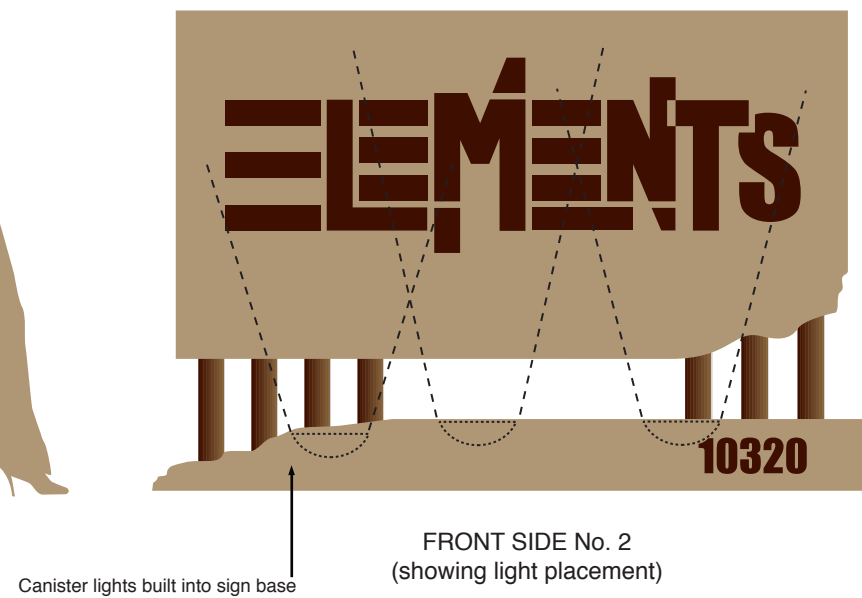
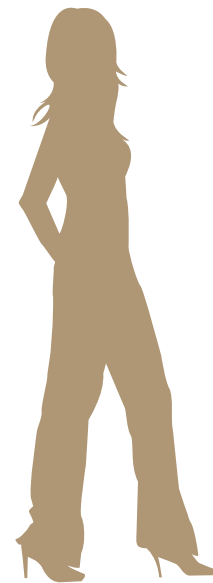
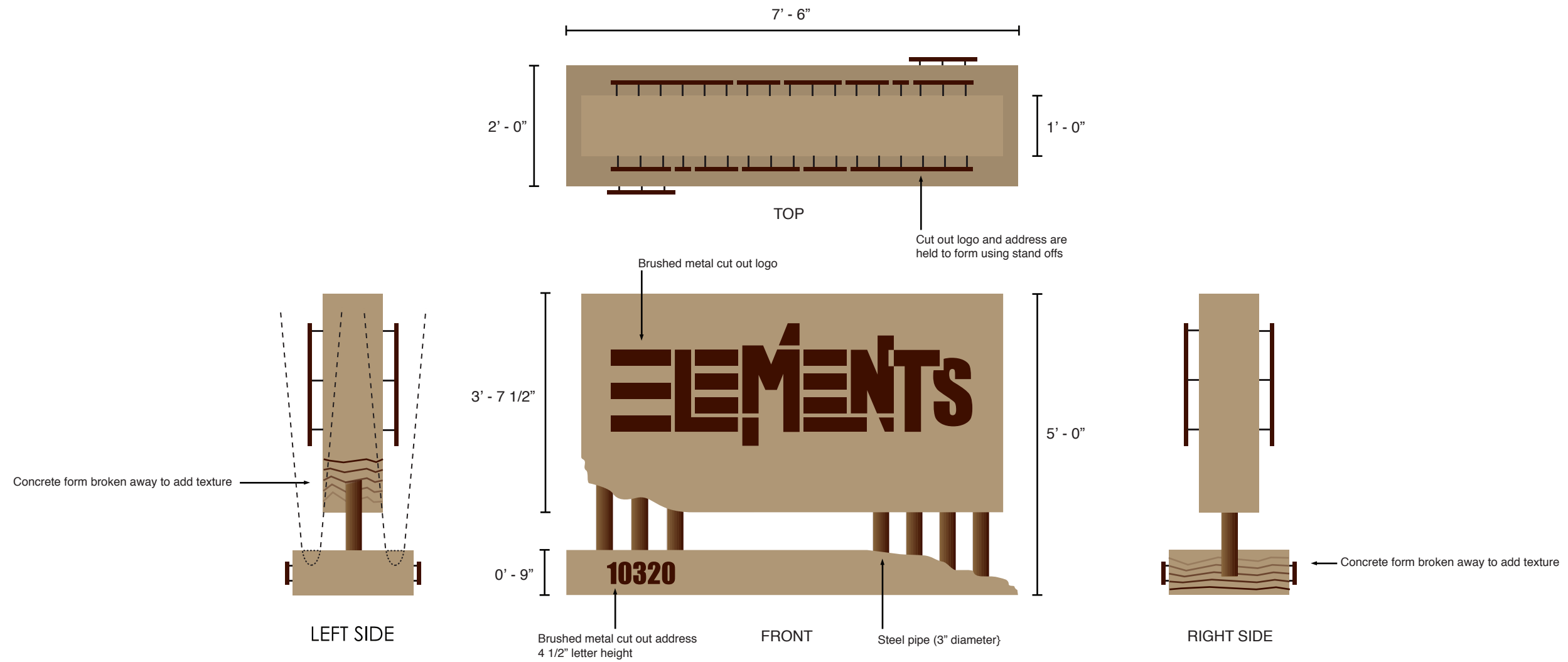

\*Dimensions and lighting of monument sign comply with the City of Scottsdale's signage codes and regulations

date 03/06/07

status FINAL

client ELEMENTS

design firm



JAMIE DAVIS  
623.398.9222  
301 W SEQUOIA DR  
PHOENIX, AZ 85027

project title  
MONUMENT SIGN

location  
10320 E DYNAMITE BLVD  
SCOTTSDALE, AZ 85262

scale 1/2"=1'-0"

All designs as well as this drawing are the property of Davis Engineering and are © 2007